

UDC 629.785:523.3

Doctor of Technical Sciences I. O. Husarova, Yu. O. Lysenko,
Doctor of Philosophy G. G. Osinovi

FUTURE PROJECTS OF LUNAR EXPLORATION IMPLEMENTED BY YUZHNOYE SDO

Over the past years, the leading space powers have been returning to the idea of expeditions to the Moon and actively designing and manufacturing components for inhabited lunar bases. Yuzhnoye State Design Office has its own concept of a lunar base and, of course, cannot stand aside from the solution of scientific and technical problems related to the Moon exploration. Specialists of Yuzhnoye SDO completed conceptual development of a significant range of technologies required for the Moon exploration: a space transportation system for lunar expeditions; landers to deliver payloads to the surface of the Moon and transport experimental equipment; mobile laboratories; a reconnaissance rover to provide reconnaissance missions on the surface of the Moon; vehicles to provide lifting and transport, assembly and construction, production and technological and soil extraction work on the surface of the Moon; habitat units and other elements of the lunar infrastructure. Taking into account the high costs of lunar exploration, it is clear that international cooperation is the most realistic scenario for Yuzhnoye SDO to participate in the exploration. The U.S. lunar program is the most attractive. Private companies that NASA selects for the lunar programs can become partners of Yuzhnoye. With a view to ensuring the participation of Yuzhnoye SDO in international programs, the current state of global technologies for the Moon exploration was analyzed and opportunities to promote technologies developed by Ukrainian specialists on the international market of space technologies were identified based on the analysis. Taking into account the high level of technologies developed by the potential partners, it is proposed for the first time to consider it advisable to promote Yuzhnoye's technologies with TRL 6–9 which have already been successfully tested and the innovative technologies developed by the company which have no analogues in the world or surpass the world level in terms of their technological and economic performance. Based on the analysis of the Lunar Industrial & Research Base conceptual design, such technologies may include rocket propulsion, units and assemblies of liquid-propellant propulsion (TRL 6–9), as well as future designs such as a hydrogen energy accumulator and inert anodes made of ultra-high-temperature ceramics for electrolysis of regolith melts.

Key words: rocket propulsion, hydrogen energy accumulator, inert anodes.

Останніми роками провідні космічні держави повертаються до ідеї експедицій на Місяць, активно проєктують і створюють складові елементи населених місячних баз. ДП «КБ «Південне» має власну концепцію місячної бази і, безумовно, не може стояти осторонь вирішення науково-технічних проблем щодо освоєння Місяця. Спеціалісти ДП «КБ «Південне» виконали концептуальне опрацювання значного спектра необхідних для освоєння Місяця технологій: космічної транспортної системи для виконання місячних експедицій; лендерів, що забезпечують доставку корисного вантажу на поверхню Місяця, а також призначених для транспортування дослідної апаратури; мобільних лабораторій; ровера-розвідника для забезпечення розвідувальних місій на поверхні Місяця; транспортних засобів для забезпечення підйомно-транспортних, монтажних-будівельних, виробничо-технологічних і ґрунто-виймальних робіт на поверхні Місяця; населених модулів та інших елементів місячної інфраструктури. Ураховуючи високі витрати на дослідження Місяця, зрозуміло, що міжнародна кооперація – найбільш реалістичний для ДП «КБ «Південне» сценарій участі в його освоєнні. Місячна програма США є найпривабливішою. Партнерами КБ «Південне» можуть стати приватні компанії, які НАСА долучає до місячних програм. Для забезпечення участі ДП «КБ «Південне» в міжнародних програмах проведено аналіз сучасного стану технологій для дослідження й освоєння Місяця у світі та на його основі визначено можливості просування розробок українських фахівців на міжнародному ринку космічних технологій. Уперше запропоновано, ураховуючи високий рівень розробок потенційних партнерів, вважати за доцільне просування технологій ДП «КБ «Південне», які вже успішно випробувано і мають рівень TRL 6–9, та інноваційних розробок підприємства, що не мають аналогів у світі або перевершують за своїми технічними й економічними показниками світовий рівень. На основі аналізу розробок концептуального проєкту місячної промислово-дослідної бази до таких технологій можна віднести ракетні двигуни, агрегати та вузли РРД (TRL 6–9), а також перспективні розробки: водневий акумулятор енергії й інертні аноди з ультрависокотемпературної кераміки для електролізу розплавлених реголіту.

Ключові слова: ракетні двигуни, водневий акумулятор енергії, інертні аноди.

Introduction

The Moon is Earth's natural satellite, which has always attracted humankind's attention. With the opening of the Space Age, the Moon exploration became an ambitious goal of humanity, with two rival world powers, the United States and the Soviet Union, contesting their primacy.

At the end of the 1970s, the winner in the Space Race to the Moon was determined, the question of prestige took a backseat, the time came for pragmatic decisions, and very expensive Moon exploration programs were curtailed both in the United States and the Soviet Union. After the first discoveries, there was a rather long period of skepticism regarding the expediency of exploring the Moon by spacecraft.

Currently, the Moon is again becoming the central point of interest for many countries. The leading space powers are returning to the idea of expeditions to the Moon, actively designing and creating components for inhabited lunar bases. Long-term stay on the Moon and construction of temporary or permanent settlements is part of the paradigm of future space exploration programs. The Moon, as the celestial body closest to Earth, is considered a component of the Earth's space infrastructure and the first of the celestial bodies connected with humanity's plans to meet its resource needs and expand space exploration.

The Lunar Industrial & Research Base will be constructed in several stages. First of all, an international collaboration for the Moon exploration should be set up, its main tasks being the development of a strategy and a joint program to create and operate the Lunar Base and provide operational management and control. Unmanned lunar exploration will also be required, such as detailed surface mapping and 3D modeling; lunar rocks composition reconnaissance and analysis; Base site selection; mobile reconnaissance rover landing on the selected site and site reconnaissance; installation of landing beacons. The Earth-Moon-Earth space transportation system (superheavy-lift launch vehicle, boosters, takeoff and landing pad) and the Lunar Base infrastructure components (Lunar Base modules, lunar rovers, power plants, a system for uninterrupted communication with Earth) should be developed.

Goal setting

Yuzhnoye SDO is a leading Ukrainian aerospace company which has its own concept of the Lunar Base and, of course, cannot stand aside from the solution of scientific and technological problems related to the Moon exploration. It is clear that Ukraine can work in this direction only in international cooperation, since the costs of design and manufacture of a life support system for future astronauts are very high. E.g., NASA plans to spend about 93 billion dollars to return to the Moon by 2025 [1].

Ensuring the participation of Yuzhnoye SDO in international programs first requires an analysis of the current state of the world lunar exploration technologies and then identification of opportunities to promote technologies developed by Ukrainian specialists on the international space technology market.

The purpose of this study is to analyze the state of technologies developed in the world for the Moon exploration and identify the areas for development of the Lunar Base concept designed by Yuzhnoye, using innovative proposals that are of interest to potential partners.

PRESENTING MAIN MATERIAL

1. Current state of the Moon exploration technologies in the world

1.1. United States of America

Today, the United States of America is reviving its ambitions to explore the Moon. With new technological development and strategic plans, the United States is asserting itself as a leader of international effort to explore our nearest space neighbor.

To return to the Moon, in 2017 the United States established the Artemis program to implement NASA's ambitious plan to put astronauts back on the Moon. The primary objective of the program is to land the astronauts on the Moon by 2025, including the first woman [2].

The Artemis program lays the groundwork to facilitate human missions to Mars. The Artemis involves the creation of the Space Launch System (SLS) rocket and the U.S.-European Orion spacecraft. Also, NASA

is working on the development of a new generation of lunar landers designed to support long-term missions and establish a permanent base on the Moon.

One of the vital components of the Artemis missions is the Gateway (International Lunar Station). This station will be an outpost for missions to the surface of the Moon, providing essential support to the astronauts and serving as a staging point for further deep space exploration. NASA is actively working with other space agencies, such as the European Space Agency (ESA) and the Japan Aerospace Exploration Agency (JAXA), to set up global collaboration in establishing and maintaining the Gateway.

NASA steps up partnering with private companies to conduct lunar exploration, in particular, with SpaceX whose space system is undergoing component-level ground tests.

The Artemis-1 mission, an uncrewed flight of the Orion capsule to the Moon on board the SLS rocket, was successfully completed on December 11, 2022 (Fig. 1). NASA plans to launch the Artemis 2 mission in 2024, which will send a crew of four astronauts around the moon. The Artemis 3 mission, tentatively scheduled for 2025, will see American astronauts land on the Moon.

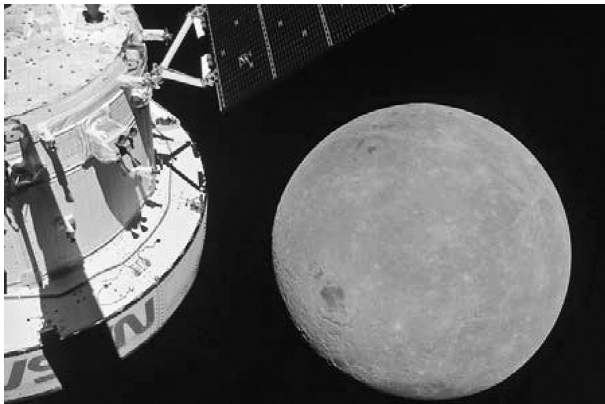

Fig. 1. The far side of the Moon looms large just beyond Orion in this image taken on the sixth day of the Artemis I mission by a camera on the tip of one of Orion's solar array wings

The United States is also actively exploring the possibility of creating a lunar economy and developing in-situ resource utilization (ISRU) technologies on the Moon, especially to mine hydrogen and helium-3, which can become a key future energy source for Earth [3].

1.2. Europe

The European Space Agency (ESA), in turn, confirms its interest in the Moon, implementing an integrated lunar program aimed at joining the efforts of the EU countries and the United States. Realizing that the Moon exploration, in particular, the construction of permanent bases will require enormous costs which European countries are unable to face on their own (neither together nor individually), ESA specialists see their future in participation in international programs (e.g., jointly with the United States).

Together with the United States, the Europeans participate in the development of the Orion spacecraft. ESA proposes to build a permanently base station on the far side of the Moon within a broad international cooperation, more extensive than the cooperation established for the ISS program.

ESA also proposed the Moonlight initiative, which involves the launch of three or four satellites into lunar orbit to give permanent coverage of the lunar surface with telecommunications and navigation services, as well as ensure communication with Earth. The satellites will first provide reliable communication and navigation for astronauts and spacecraft at the Moon's south pole where the first permanent base camp for lunar explorers will be situated.

With its technological innovation and strategic vision, Europe is becoming an important player in the global effort to explore the Moon. Current research and development level confirms that Europe is ready to contribute to the future of space exploration and lunar colonization.

ESA is currently preparing a lunar surface mission to demonstrate technologies needed to enable ISRU on the Moon [4].

1.3. China

China is still the only country in the world that carries out expensive lunar exploration programs independently.

China's current technological advances and ambitions in space exploration make it one of the key players in the global effort to explore Earth's natural satellite.

A key element in Chinese lunar exploration program is the Changzhen-6.9 heavy-lift rocket

which allows sending spacecraft with large research facilities to the Moon.

Four independent lunar exploration projects by automatic stations have been implemented so far, including landing a Moon rover on the lunar surface. An impressive achievement was the successful Chang'e-5 lunar sample return mission which collected samples of lunar rocks and soil. This historic event highlighted China's technological maturity and scientific potential in lunar exploration.

China has expressed ambitious plans to build a lunar base and infrastructure for future missions. China is actively developing technologies for mining resources on the Moon. One of the key areas of exploration is the search for water which could serve as a valuable resource for life support and fuel production.

Space research firm Euroconsult estimates China spent \$12 billion on its space program in 2022 [1, 5, 6].

1.4. India

India also has a lunar component in its space exploration program. The country landed an automatic probe on the Moon and flight-tested a full-scale mock-up of the crew capsule.

On July 14, 2023, India launched the Chandrayaan-3 spacecraft (with the Pragyaan rover on board), which soft landed on lunar surface on August 23, 2023 (Fig. 2).



Fig. 2. Launch vehicle with the Chandrayaan-3 on board

The Chandrayaan-3 mission is designed to demonstrate end-to-end capability in safe landing and roving on the lunar surface.

India became the fourth country in the world that achieved such a feat (after the Soviet Union, United States, and China), and the first to land on the rugged south pole of the Moon. The mission cost is estimated at nearly \$73 million.

India is examining the possibility to include in its long-term plans the delivery of a scientific research station to the Moon and perform crewed flights to the Moon and Mars, independently or with the help of international partners.

The Indian Space Research Organization has begun studying inexpensive but practical ways of building habitable lunar modules. Previously, a team of scientists participating in the project developed an automatic interplanetary station that was sent to Mars and successfully entered its orbit. At the same time, the development team spent almost ten times less money than specialists in the United States when implementing a similar project.

1.5. Japan

Japan launched an automatic probe and an unmanned landing module to the Moon and is conducting conceptual development on a future multipurpose crewed ship.

Japan became the fifth country to land an explorer on the lunar surface after the former Soviet Union, the United States, China and India amid intensifying global competition in space. On January 20, 2024, the Japanese Aerospace Exploration Agency made a successful landing of the unmanned SLIM probe, first lunar landing in the country's history [7].

Japan is one of the world's most advanced countries in space technology, with its state-of-the-art launch vehicles of all weight classes, from small- to heavy-lift, its own Kibo Experiment Module on the ISS (the largest on board) and Kounotori HTV cargo spacecraft to resupply the ISS.

In the past, Japan announced its plans to create its own base on the Moon, but these initiatives have not yet been implemented. At the same time, Japan is participating in international negotiations with partners on the International Space Station (United States, Canada and ESA) about implementation of a project to create a joint orbital lunar station to be based on the ISS and used as a first interplanetary ship.

In future lunar missions, if developed, Japan will use the experience gained during the implementation of the Hayabusa missions that explored asteroids.

The Japan Aerospace Exploration Agency (JAXA) has officially partnered with the Japanese automotive giant Toyota Motor

Corporation to create the pressurized self-driving rover for exploring the lunar surface. Japan hopes to launch the lunar surface mission as early as 2029.

JAXA plans to develop robots and other technologies that will help in building and maintaining inhabited bases on the Moon and Mars. Another challenge for JAXA is to develop technologies that will allow the extraction of necessary building materials, such as iron and aluminum, directly on the Moon and Mars, as well as to find a way to get drinkable water from ice. For example, JAXA selected an idea proposed by the Japanese corporation Kajima to develop fully automated construction machinery for building a facility (Space Exploration Innovation Hub) to accommodate four to six people on the Moon in around 2030 and on Mars in around 2040.

1.6. Other countries

29 countries have already joined the international Artemis program established by the United States in 2017: Australia, Canada, Italy, Japan, Luxembourg, the United Arab Emirates, Great Britain, Ukraine, etc. [8].

Russia also has a federal space program, which defines two areas of lunar exploration: unmanned and manned. However, the project schedules were constantly changing, and the funding was slashed several times. After the Soviet Union collapse, Russia failed to implement any of its few scheduled interplanetary missions (Mars-96, Fobos-Grunt), and no attention was paid at all to the Moon exploration. Another attempt to fly to the Moon (AMS Luna-25), made in August 2023, 47 years after the Luna-24 station, ended unsuccessfully [1].

The Russian Federation has the Angara-A5B heavy-lift launch vehicle and a manned transport spacecraft under development and in development test phase.

1.7. Ukraine

Ukraine has its own concept of a lunar base, which was created by the specialists of Yuzhnoye SDO under the leadership of Olexandr Degtyarev, General Designer – General Director of the company in 2010–2019 (Fig. 3).

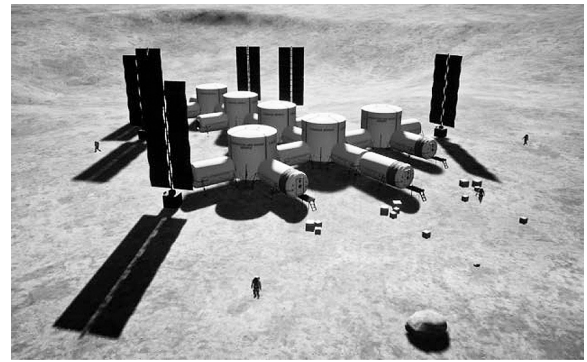

Fig. 3. Yuzhnoye's Lunar Industrial & Research Base concept

Yuzhnoye SDO initiated a number of studies on lunar technologies even before the topic became a major trend worldwide.

A settlement on the Moon and interplanetary missions were the cherished dreams of Olexandr Degtyarev and determined Yuzhnoye's path of development in this domain.

Yuzhnoye specialists developed the lunar base design, determined the strategy of its creation, defined configuration and infrastructure at various stages of operation project implementation schedule, made studies for the transportation space system for unmanned and manned missions, typical design of the lunar base modules and derived inhabited modules for various applications, defined a general concept of the technology for lunar module unloading, installation and assembly, developed lunar orbital vehicles and lunar rovers, assessed preliminary cost/performance ratios and financial viability of the project.

The concept of the Yuzhnoye Lunar Base was presented at a number of international events where it received a lot of positive feedback, including for a wide range of issues addressed in it.

So, the analysis of the current state of the world technology market when it comes to the Moon exploration showed that the United States, China and the Russian Federation have their own super-heavy-lift and heavy-lift launch vehicles currently available or in development and ground test phase.

NASA is actively working with other space agencies such as ESA and JAXA to set up global collaboration in establishing and maintaining the Gateway.

Japan and Ukraine have made conceptual designs for future launch vehicles and spacecraft to bring cargoes to the Moon.

2. Lunar Technologies developed by Yuzhnoye SDO

The Lunar Base is one of the most global, expensive, knowledge-intensive and time-consuming project that humanity will have to implement in the near future. The Base should be created gradually and consistently, verifying and acknowledging each step, each mission, to make sure that all its component parts are ultra-reliable.

Yuzhnoye specialists performed a conceptual study of a wide range of technologies required for the Moon exploration.

The principal system to support the creation of the lunar infrastructure is the Space Transportation System for lunar expeditions, both crewed and cargo delivery. Based on the analysis of the current state of development of heavy-life and super-heavy-life launch vehicles in Yuzhnoye, an asymmetric two-launch approach was chosen for lunar expeditions. Yuzhnoye's Lunar Space Launch System (MRKS) consists of the Lunar Expeditionary Complex (MEK), designed for manned expeditions to the surface of the Moon, and the Lunar Transportation Complex (MTK), designed to deliver heavy cargo to the surface of the Moon (Fig. 4, a, b).

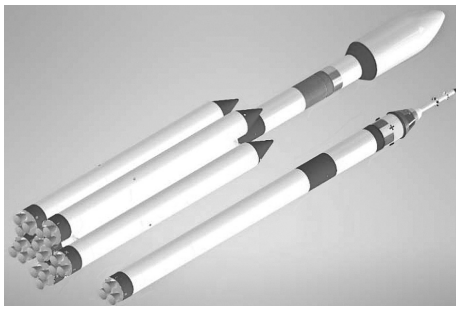

a – Medium-lift Mayak-S3.9 ILV and super-heavy-lift Mayak-ST6 ILV

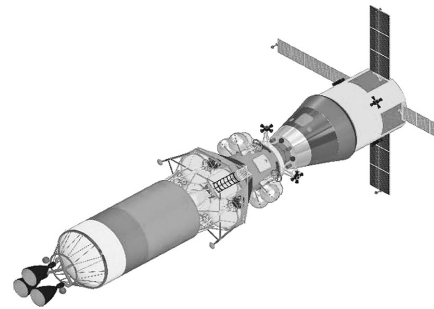

b – Lunar Expeditionary Complex (MEK) in the initial phase of the flight to the Moon

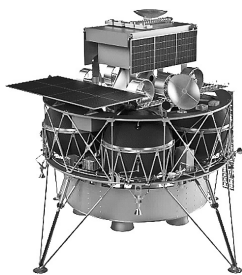

c – Lander for the study of the Moon's surface

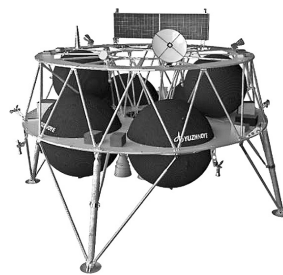

d – Lander for cargo delivery

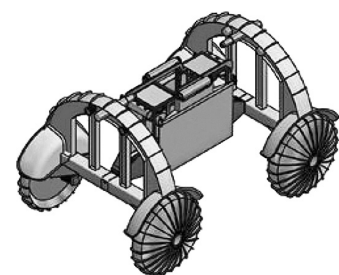

e – Reconnaissance rover



f – Rovers for handling/transport, assembly/construction, production/support and soil extraction work on the Moon's surface

Fig. 4. Principal components of the Lunar Space Launch System (a, b) and Yuzhnoye's Industrial & Research Base infrastructure (c-f)

The MRKS includes:

- Space launch system with the Mayak-S3.9 medium-lift integrated launch vehicle (ILV)
- Space launch system with the Mayak-ST6 super-heavy-lift ILV
- Manned spacecraft
- Lunar spacecraft
- Landing module based on a heavy universal lander
- Lunar booster stage
- Heavy universal lander
- Lunar space tug.

The conceptual design of the Lunar Base also includes concepts for the landers to deliver payloads to the surface of the Moon: the flying lunar lander is designed to study the surface of the Moon at several points during one expedition, see Fig. 4, c; the lunar lander to deliver research equipment, mobile laboratories, or cargo for the Lunar Base to the surface of the Moon, see Fig. 4, d; the reconnaissance rover to provide reconnaissance missions on the surface of the Moon; rovers for handling/transport, assembly/construction, production/support and soil extraction work on the Moon's surface, see Fig. 4, e and f; vertical and horizontal habitats and other elements of the lunar infrastructure (Fig. 3).

The large number of the components developed for the lunar infrastructure indicates the significant potential and readiness of Ukraine to participate in the global Moon exploration project applying advanced technologies and scientific achievements.

3. The place of Yuzhnoye's technologies in international Moon exploration projects

Construction of the Lunar Industrial & Research Base is a challenging and expensive scientific and technological task involving high overall risks due to insufficient reliable information about the Moon and technology risks due to inadequate skills and longer lead times in development and manufacture of individual components.

It should be noted that the initial stage of the Moon exploration will be extremely expensive. That is why the countries are currently investing in the research to explore lunar resource utilization.

Since the draft Law of Ukraine «On the Approval of the National Targeted Scientific

and Technical Space Program of Ukraine for 2023–2026» does not provide for the allocation of funds for the lunar program, the actual lunar projects can be implemented by Ukrainian developers only in cooperation with companies from other countries.

It follows from the study of the world market that international cooperation is the most realistic scenario for Yuzhnoye to participate in the Moon exploration. The United States lunar program is the most attractive. American private companies which NASA works with in the lunar programs can become Yuzhnoye's partners.

In view of the high level of development of potential partners, it is advisable to promote Yuzhnoye's technologies that make up large systems being developed by space exploration and lunar exploration leaders, Yuzhnoye's technologies which have already been successfully tested and have TRL 6–9, and Yuzhnoye's innovative technologies that have no analogues in the world or surpass the world level in terms of their technological and economic performance.

The analysis of the developed Lunar Industrial & Research Base conceptual design shows that such technologies may include rocket propulsion, liquid-propellant propulsion units and assemblies (TRL 6–9), as well as future designs such as a hydrogen energy accumulator and inert anodes made of ultra-high-temperature ceramics for electrolysis of regolith melts.

3.1. Propulsion systems and associated assemblies and subsystems

Yuzhnoye SDO developed jet rocket engines for various applications, as well as individual components of the propellant feed system such as:

- The RD840 main engine is designed for apogee stages and spacecraft (Fig. 5). The RD840 is a single-chamber, fixed-thrust, restartable pressure-fed engine (TRL 7).

- The single-chamber restartable RD860 engine with a pneumatic feed system is designed for booster stages, space tugs and unmanned landing and take-off modules (Fig. 6). Most of the engine assemblies and subsystems (including the chamber and the pneumatic pump assembly) have passed prototype development tests (TRL 7).

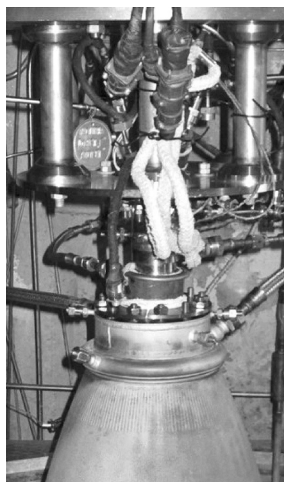

Fig. 5. RD840 engine assembly



Fig. 6. RD860 engine assembly

- Subsystems for various types of turbopump and pump assemblies.

- Assemblies for control units operating in cryogenic and high-boiling propellants, high-temperature and high-pressure gases.

- Assemblies for high-pressure cylinders and propellant tanks used in pressure-fed liquid-propellant rocket engines.

- Assemblies for liquid-propellant rocket engine gas generators and chambers.

All the above designs meet world-class standards. Their development at Yuzhnoye (in cooperation with Ukrainian partner companies) has significant advantages:

- Closed development cycle (design, design documentation release, manufacture, tests) of various types of engines.

- Competitive cost of development.

- In-house manufacture and test facilities.

The engine assemblies and the propellant feed system components can be used to equip spacecraft and landers designed to deliver cargo to the surface of the Moon and Mars, including within the framework of NASA's Artemis program.

Potential customers can be government organizations and private companies in the United States, Europe, Japan and other countries, including those working in the Artemis program (NASA, Lockheed Martin, Venturi Astrolab, Northrop Grumman, Firefly Aerospace, Moon Express, Sierra Nevada Corp., etc.)

3.2. Hydrogen energy accumulator

The best option for power supply of the Lunar Base during the lunar night is using

excess energy from the Sun, accumulating as hydrogen and oxygen obtained by water electrolysis during the lunar day.

Ukrainian specialists have created an innovative water electrolysis technology based on a high-pressure membraneless electrolyzer, whose energy efficiency is 10–20 % higher than in the best models of traditional electrolyzers thanks to the absence of membranes. The technology was tested on laboratory models (Fig. 7).

Adapting the high-pressure membraneless electrolyzer to operation in outer space requires a sharp reduction in operating currents and, on this basis, a reduction in ohmic losses in bus bars.

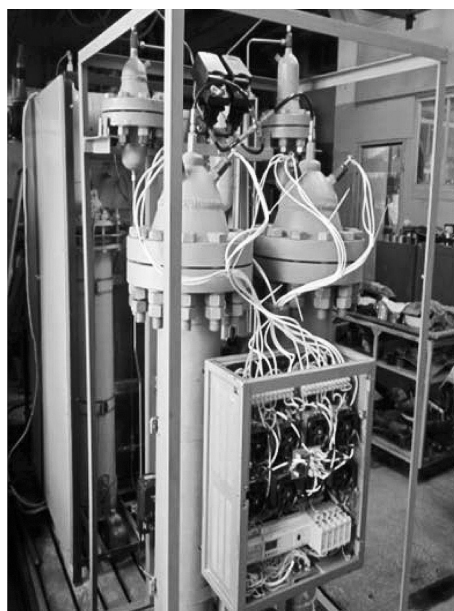

Fig. 7. Laboratory model of hydrogen energy accumulator

For this purpose, a voltage drop across the electrodes should be increased from the existing 1–1.5 V to 30–40 V.

Theoretical and experimental work carried out on parallel and serial connections of the electrode assemblies of the membraneless electrolyzer showed that the only method of increasing its operating voltage is to use a hybrid connection circuit, in which the monopolar cells of the electronic assemblies are connected in series with simultaneous insulation of the electrolysis volumes of each cell.

The main feature of the proposed innovative electrolyzer technology is the temporal separation of the processes of hydrogen formation and oxygen formation, which

prevents the mixing of gases in the electrolyte and the formation of an explosive mixture.

For the first time, the proposed technology actually bypasses and eliminates the main problems in using existing hydrogen and oxygen generation technologies on the Moon's surface: large size, heavy weight, cost of delivery of the compression equipment to the surface of the Moon, as well as the complexity of maintaining such equipment once delivered.

Government and private companies developing power supply and residential infrastructure for exploring other planets, including those working in the Artemis program (NASA, Lockheed Martin, Lunar Resources, etc.) may become potential customers of this technology.

The research conducted by Ukrainian specialists essentially paves the way for the development of prototypes for using this technology in space hardware and high-capacity industrial-scale plants.

3.3. Ultra-high-temperature ceramics for anodes

The main raw material for obtaining oxygen and various construction materials is the lunar soil, or regolith. One of the promising technologies, which are developed to determine the degree of their applicability in space missions, is to generate the materials by electrolysis of oxides that are part of most planetary rocks and soil.

The most attractive is molten regolith electrolysis, which offers a single, one-step process for separating oxygen from metals by direct electrolysis of molten oxides and requires virtually no import of consumables from Earth. A current problem in such systems is the rapid loss of physical characteristics of the anode material due to the release of oxygen, which leads to a relatively short life cycle of the installation.

For the first time, a solution to this problem was proposed using anodes made of high-temperature ceramics, which are resistant to the active oxygen in the working temperature range and have sufficient electrical conductivity.

Such composite ultra-high-temperature ceramics (UHTC) of the ZrB_2-SiC ($ZrSi_2$) and ZrB_2 ($MoSi_2$) system for anodes were developed and researched by Ukrainian specialists [9, 10].

The obtained UHTC is heterogeneous (Fig. 8). Residual porosity does not exceed 5 %.

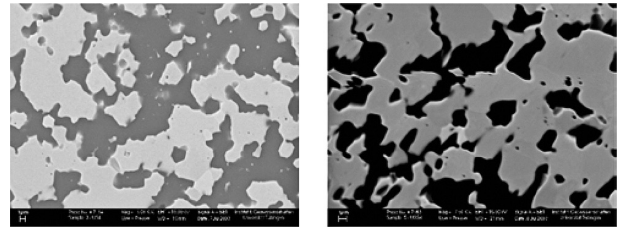

Fig. 8. $ZrB_2-SiC(ZrSi_2)$ system ceramics microstructure with different compositions

Tests of the ZrB_2-SiC and $ZrB_2-SiC-ZrSi_2$ UHTC for high-temperature oxidation resistance in a pure oxygen environment were run in a furnace at 1500 °C for 50 hours.

It was demonstrated that adding $ZrSi_2$ to the ZrB_2-SiC ceramics increases its resistance to oxidation (Fig. 9). The maximum resistance to oxidation is observed with the addition of 2 vol.% $ZrSi_2$.

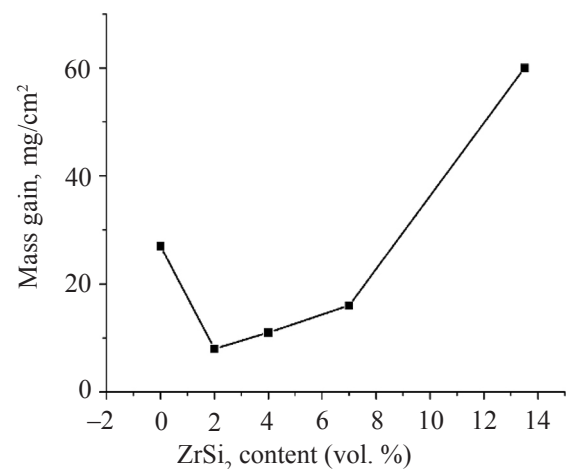

Fig. 9. Mass gain vs. $ZrSi_2$ content (vol. %) in the charge for oxidation at 1500 °C for 50 h in oxygen

Ukraine developed a technology for manufacturing structures from ZrB_2 based ceramics, such as:

- Processing methods for hot pressing of ceramic plates have been developed;
- Pilot experimental and industrial production of ceramic products of the $SiC-ZrB_2-ZrSi_2$ i ZrB_2-MoSi_2 system was organized, which can be used for the manufacture of inert anodes for the regolith melts electrolysis on the Moon.

Advantages of the technology:

- Long-term direct electrolysis of regolith melts at 16000 °C, which does not require consumables;

- Increased life cycle of the system;
- Competitive cost;
- In-house manufacture and test facilities.

Potential customers of the technology can be government and private companies developing power supply and residential infrastructure for exploring other planets, including those working in the Artemis program (NASA, Lockheed Martin, Lunar Resources, etc.)

Conclusions

For the first time, an analytical study of the current state of lunar exploration technologies developed by world's space industry leaders was conducted to identify the prospects of Yuzhnoye SDO's participation in international cooperation. It is shown that today, both in space and on Earth, the main competitors are China and the United States.

Yuzhnoye specialists analyzed and performed a conceptual study of a wide range of technologies required for the Moon exploration

Taking into account the high level of technologies developed by the potential partners, it was proposed for the first time to consider it advisable to promote Yuzhnoye's technologies with TRL 6–9 which have already been successfully tested and the innovative technologies developed by the company which have no analogues in the world or surpass the world level in terms of their technological and economic performance.

Based on the analysis of the Lunar Industrial & Research Base conceptual design, such technologies may include rocket propulsion, units and assemblies of liquid-propellant propulsion (TRL 6–9), as well as future designs such as a hydrogen energy accumulator and inert anodes made of ultra-high-temperature ceramics for electrolysis of regolith melts.

References

1. Росія втратила «Луну-25», Індія успішно завершила місію. Чому країни поновили гонку за ресурси Місяця? 23 серпня 2023. <https://www.epravda.com.ua/publications/2023/08/23/703510> (Russia lost Luna-25, India successfully completed the mission. Why have countries renewed the race for lunar resources? August 23, 2023. In Ukrainian).

2. Creech S, Guidi J, Elburn D. Artemis: An overview of NASA's activities to return humans to the Moon. Paper presented at: 2022 IEEE Aerospace Conference (AERO); 2022 Mar 05–12; Big Sky, Montana.

3. In-Situ Resource Utilisation (ISRU) Demonstration Mission, 2019. <https://exploration.esa.int/web/moon/-/60127-in-situ-resource-utilisation-demonstration-mission>.

4. Peng Zhang, Wei Dai, Ran Niu, Guang Zhang, +12 authors. Overview of the Lunar In Situ Resource Utilization Techniques for Future Lunar Missions. *Journal Space: Science & Technology*. 2023, Vol. 3, P. 1–18. Article ID: 0037. DOI: 10.34133/space.0037

5. Lin XU, Hui LI, Pei Z, Zou Y, Wang C. A brief introduction to the International Lunar Research Station Program and the Interstellar Express Mission. *Chinese J Space Sci*. 2022;42(4):511–513.

6. Li C, Wang C, Wei Y, Lin Y. China's present and future lunar exploration program. *Science*. 2019;365(6450):238–239.

7. Укрінформ, 09 січня 2024, <https://www.ukrinform.ua/rubric-technology/3804665-aponskij-zond-uvijsov-do-orbiti-misaca-pered-posadkou.html> (Ukrinform, January 9, 2024. In Ukrainian).

8. Німеччина приєдналася до програми вивчення Місяця Artemis, 15.09.2023, <https://www.dw.com/uk/nimeccina-priednalas-do-programi-vivcenna-misaca-artemis/a-66826693> (Germany joined the Artemis moon exploration program, September 15, 2023. In Ukrainian).

9. Григорьев О. Н., Фролов Г. А., Евдокименко Ю. И., Кисель В. М., Панасюк А. Д., Мелак Л. М., Котенко В. А., Коротеев А. В. Ультравысокотемпературная керамика для авиационно-космической техники, *Авиационно-космическая техника и технология*, 2012, No 8 (95), с. 119–128 (O. N. Grigoriev, G. A. Frolov, Yu. I. Evdokimenko, V. M. Kisel, A. D. Panasyuk, L. M. Melakh, V. A. Kotenko, A. V. Koroteev. Ultra-high-temperature ceramics for aerospace engineering, *Aerospace engineering and technology*, 2012, No. 8 (95), P. 119–128. In Russian).

10. Grigoriev O. N. et al. Oxidation of $ZrB_2-SiC-ZrSi_2$ ceramics in oxygen. *Journal of the European Ceramic Society* 30 (2010). 2397–2405.